

FOR REFERENCE ONLY

ALL MATERIALS ARE 304 STAINLESS STEEL

STANDARD KEYSETS	
DIA. OF SHAFT (BORE DIA. OF SPROCKET)	KEYSEAT (WIDTH x DEPTH)
3/4" to 7/8"	3/16" x 3/32"
15/16" to 1-1/4"	1/4" x 1/8"
1-5/16" to 1-3/8"	5/16" x 5/32"
1-7/16" to 1-3/4"	1/4" or 5/16" SEAT
1-13/16" to 1 15/16"	1/4" or 5/16" SEAT

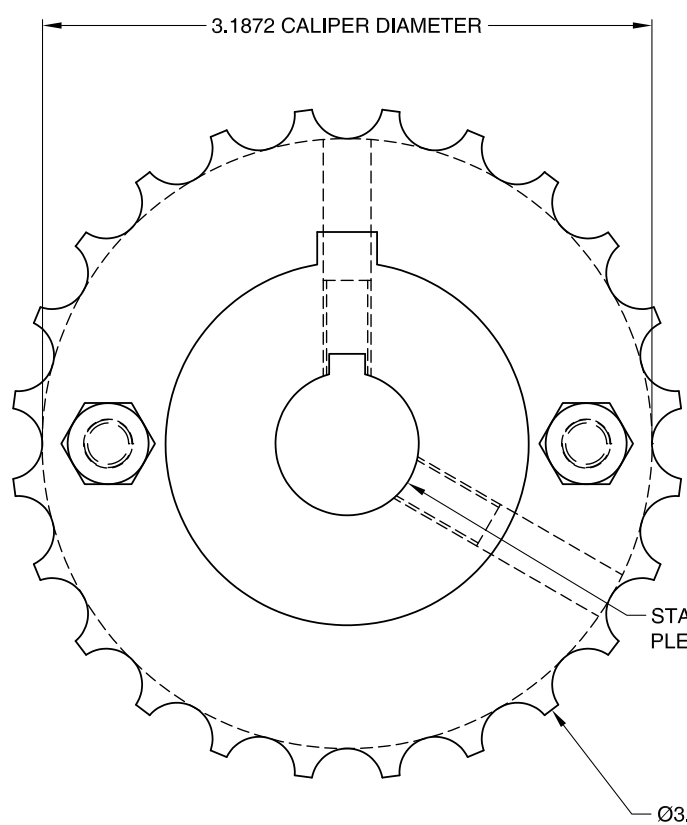

STANDARD 3/4" BORE DIAMETER SHOWN WITH STANDARD KEYSEAT. PLEASE SPECIFY REQUIRED BORE DIAMETER AND KEYSEAT.

BORE DIAMETER	KEYSEAT

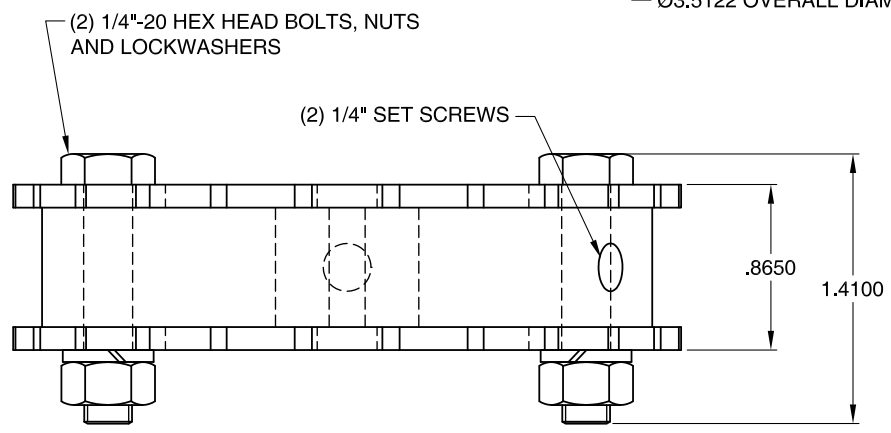

NOTES:

1. PLEASE NOTE THAT 1 15/16" BORE DIAMETER WITH A 5/16" x 5/32" KEYSEAT IS THE MAXIMUM SIZE ALLOWED FOR THIS SPROCKET DESIGN. LARGER BORE DIAMETERS WILL REQUIRE RE-ENGINEERING OF SPECIAL SPROCKET.

<p>NOTICE: THIS DRAWING IS THE PROPERTY OF THE WIRE MESH BELT COMPANY AND MAY NOT BE COPIED OR REPRODUCED IN ANY FORM, OR USED FOR MANUFACTURING PURPOSES OF ANY KIND WITHOUT THE EXPRESSED WRITTEN CONSENT OF THE WIRE MESH BELT COMPANY.</p>	<p>CUSTOMER INFORMATION</p>	<p>WIRE MESH BELT COMPANY 170 SUMMERLEA ROAD, BRAMPTON, ONTARIO L6T 4X3 www.wremeshbelt.com "CUSTOM WOVEN BELTS SINCE 1966"</p>													
	<p>P.O. #</p>			<p>TITLE</p> <p>24 TOOTH SPROCKET B-48-52 MESH SPECIFICATION</p>	<p>REV</p> <p>0</p>	<p>SCALE</p> <p>1:1</p>									
<p></p> <p>ALL DIMENSIONS ARE INCHES UNLESS OTHERWISE SPECIFIED</p>	<p>W.O.#</p>	<p>TOLERANCE UNLESS OTHERWISE SPECIFIED</p> <table border="0"> <tr> <td>DECIMAL .X</td> <td>±.03</td> <td>FRACTIONAL ± 1/16</td> </tr> <tr> <td>.XX</td> <td>±.015</td> <td></td> </tr> <tr> <td>.XXX</td> <td>±.005</td> <td>ANGULAR ± 1/2°</td> </tr> <tr> <td>.XXXX</td> <td>±.0005</td> <td></td> </tr> </table>		DECIMAL .X	±.03	FRACTIONAL ± 1/16	.XX	±.015		.XXX	±.005	ANGULAR ± 1/2°	.XXXX	±.0005	
DECIMAL .X	±.03	FRACTIONAL ± 1/16													
.XX	±.015														
.XXX	±.005	ANGULAR ± 1/2°													
.XXXX	±.0005														
<p>DATE</p> <p>05/29/03</p>		<p>DRAWING</p> <p>G4852-24</p>													
<p>DRAWN BY</p> <p>MP</p>															